



LARGEST NETWORK



XGC80-I

CRAWLER CRANE



SCHWING STETTER (INDIA) PRIVATE LIMITED

F71/72 SIPCOT Industrial Estate, Irungattukottai, Kanchipuram District - 602117, Tamil Nadu, India.

GIN No. U45309TN1998PTC046270

Mobile: +91 9176644659; Landline: +91 (44) 71378106

kc.sharma@schwingstetterindia.com

www.schwingstetterindia.com



Toll 1800-123-1479

Note: This catalogue may contain attachments and optional equipment that may not be available in your area and it may contain photographs of machines with specifications that may differ from those of the machines sold in your territory. Please consult your nearest Schwing Stetter - XCMG dealer for any information on those items you require. Due to our policy decision on continuous product improvements, all designs and specifications are subject to modifications without permission.

Copyright by Schwing Stetter India Pvt Ltd; No part of this catalogue shall be reproduced anywhere in whatsoever format without consent by SSIPL.



CONTENTS

P02	• PARTS AND SYSTEM DESCRIPTION OF THE CRANE • SAFETY PROTECTION MEASURES • MAIN TECHNICAL PARAMETERS
P10	• Lifting Capacity Tables in Typical Working Conditions
P21	• TRANSPORT PLAN OF CRANE PARTS

02

XGC80-I CRAWLER CRANE

P03-P05	PARTS AND SYSTEM DESCRIPTION OF THE CRANE
P06-P07	SAFETY PROTECTION MEASURES
P08-P09	MAIN TECHNICAL PARAMETERS

PARTS AND SYSTEM DESCRIPTION

Crane superstructure

Boom combination

The boom sections of XGC80-I crawler crane use high-strength seamless steel pipes as main chords and lacing members, supplemented by four-chord lattice structure welded by high strength steel plate, with equal section in the middle and variable section at two ends. With the help of accurate finite element analysis and calculation, the potential of boom sections are fully utilized and the lifting capacity is greatly improved.

In boom working condition, the maximum lifting capacity is 85t/3.6m, the maximum load moment is 288t.m, boom length 13m~58m. Boom composition: boom butt 1 × 6.5m, boom top 1 × 6.5m, boom insert 1 × 3m, boom insert 1 × 6m, boom insert 4 × 9m.

In fixed jib working condition, the maximum lifting capacity is 12.0t (parts of line 2), the maximum load moment is 10.7t × 16m=171.2t.m, boom length 28m~43m, fixed jib length 7m~19m. Fixed jib composition: jib butt 1 × 4m, jib top 1 × 3m, jib insert 2 × 3m, jib insert 1 × 6m, strut 1 × 3m.

In boom single top working condition, the maximum lifting capacity is 6.5t (parts of line 1), boom single top length is 1.1m, boom length 13m~58m.

Boom luffing components

Luffing connection between boom sections is mainly realized through guy cables, supplemented by pendant. The guy cables adopt mature structure, safe and reliable; the pendants use high-strength steel plate and cut once for formation, no welding, with less manufacturing defects and has high safety factor.

Turntable

Turntable is the key load bearing structure to connect superstructure and undercarriage, the main bearing structure is made of high strength steel plate and welded in flat box-type structure, the space of the crane is enlarged by welding bracket on both sides for arranging the fixed load. Turntable is connected with undercarriage by slewing ring. Boom butt, gantry, hoist winch, luffing winch and counter-weight are arranged on main bearing structure; cab, engine system, main pump, hydraulic valve, electric cabinet and other structures are arranged on the brackets on both sides; turntable main structure and brackets of both sides are designed according to the force condition of the overall crane, with reasonable structure, good overall strength and stiffness.

Gantry

Gantry is double-limb structure, reinforced beam is installed between the two limbs, with good stability. The main structure of gantry is high-quality seamless steel pipe, with less welding, less manufacturing defects and high safety factor. The gantry is equipped with self-erection roller, which can achieve self-erection function under the coordination of boom butt.

Mechanism composition

The mechanisms of the crane and their functions are shown in the table below:

Main hoist mechanism	Lifting operation with main boom	Middle and front part of turntable
Aux. hoist mechanism	Lifting operations in boom single top and fixed jib working conditions	Middle part of turntable
Boom luffing system	Lifting operation with main boom	Rear part of turntable
Slewing gear	Used for super-structure slewing	Front part of turntable
Travel gear	Used for crane travel	Crawler drive sprocket

Hoist system

Hoist system includes main hoist system and aux. hoist system.

For main and aux. hoist systems, planetary reducer is driven by fixed displacement motor to achieve the hoisting and lowering of main or auxiliary hook block through drum and pulley block. The speed of main and auxiliary hoist winches is increased through double-pump soil supply function.

The hoist mechanisms have built-in planetary reducer, with negative brake wet type multi-disc normally closed brake, to achieve "spring braking/hydraulic release" function, safe and reliable. Splash lubrication is adopted, free for maintenance. The hoist winches also have the features of easy oil replacement, low noise, high efficiency and long service life. It also has good fine motion performance.

The ductile iron double-line drum is used for the winches, with good vibration absorption, ensures that there is no messy rope when it is reeved in multiple layers, which effectively prolong the rope's service life.

The rotation resistance wire rope used for main hoist winch is left-handed and twisting in the same direction. It has the features of independent steel core, high breaking force and high extrusion resistance. Rated single line pull is 6.5t, rope diameter is $\phi 20$ mm, rope length is 240m.

The wire rope used for auxiliary hoist winch is also rotation resistance, with the features of independent steel core, high breaking force and high extrusion resistance. Rated single line pull is 6.5t, rope diameter is $\phi 20$ mm, rope length is 140m.

Main and auxiliary hoist winches are both optionally configured with free fall function, under no-load working condition, the hook can lower quickly.

Luffing system

For the luffing winch system, planetary reducer is driven by fixed displacement hydraulic motor to achieve boom luffing through drum and luffing pulley block.

Luffing mechanism has built-in planetary reducer, with negative brake wet type multi-disc normally closed brake to achieve "spring braking/hydraulic release" function.

The ductile iron double-line double-drum is used for main luffing winch, with good vibration absorption, ensures that there is no messy rope when it is reeved in multiple layers, which effectively prolong the rope's service life. The drum has a ratchet locking device, and the pawl is driven by hydraulic cylinder to achieve multiple lock for protection.

The rotation resistance wire rope used for the luffing system is left-handed and twisting in different directions. It has the features of independent steel core, high breaking force and good structure stability. Rated single line pull is 6t, rope diameter is $\phi 20$ mm, rope length is 135m.

Slewing unit

Slewing unit is internally meshed with slewing ring for drive. It is arranged in front of turntable. Planetary reducer is driven by fixed displacement motor to drive the slewing ring to achieve 360° slewing.

Slewing unit has a built-in planetary reducer, with negative brake wet type multi-disc normally closed brake to achieve "spring braking/hydraulic release" function, so as to ensure high brake safety. Slewing unit also has a mechanical locking device for locking protection of the slewing unit.

Eccentric mechanism can ensure a better meshing between the reducer and slewing bearing, so the slewing is more stable. The slewing mechanism has free swing function, so when heavy load is lifted, the side force of boom can be eliminated even if the hook is not on the vertical center line of the gravity center of the heavy load, so as to prevent boom from being damaged due to large side force.

Slewing bearing

Double-row ball type slewing bearing with elliptical raceway, it has the features of large bearing capacity, small slewing resistance, wear resistance and long service life.

Cylinder assembly

It includes track frame telescopic cylinder and boom luffing ratchet lock cylinder.

Oil cylinder is used as the power to extend or retract the crawler tracks, it shares the same main valve with left crawler travel. The interchange between travel and crawler track extension/retraction is convenient, the action is soft with small impact. The track gauge of the crane is easy to change to meet the requirements of transportation and working.

Boom luffing ratchet lock cylinder is used to control the ratchet pawl. When operating boom luffing pilot handle, the pawl will open automatically, and when the pilot handle returns to the neutral position, the pawl will close automatically. When boom luffing winch is not working, the ratchet lock device is always in the locked state, no need of any manual operation, which is much safer.

Operator's cab

The model of cab adopts the method of bionic design, with smooth lines and a sense of power. The glass area is larger and the distribution of side glass is more reasonable, with stronger sense of technology and wider field of vision. The interior is arranged by the concept of human-centered, so the driver can touch all the buttons without leaving the seat. The cab is also set with adjustable seat, air conditioning, power socket, radio and so on to provide the operator with a comfortable operating environment.

PARTS AND SYSTEM DESCRIPTION

Crane undercarriage

Crane undercarriage comprises car-body and crawler travel unit. Car-body is inserted into crawler travel device for connection.

Car-body

Car-body is radial box structure, welded by high strength steel plate, with features of good rigidity, high strength and high precision. The upper plane is precision machined to make sure the slewing bearing is correctly installed.

Crawler travel unit

Crawler travel unit is divided into left and right crawler tracks, consisting of track frame, track shoe, track roller, drive sprocket, guide roller, carrier roller, travel device and tension device.

Track frame: symmetrically arranged, one piece for each side. It is made of high-strength steel plate and welded in box-type structure. Car-body is inserted into track frame for connection. Drawer type device is used for upper and lower clearance adjustment to make sure no lateral deviation after track frame installation, so as to avoid wear between track shoe and track roller.

Track shoes: high strength wear-resistant alloy steel casting, the crawler shoe width is 760mm, total 2 × 63=126 pieces.

Travel unit: constant closed planetary reducer, driven by axial piston motor. It has strong travel power and can achieve movements such as straight-line travel, steering at a position, one side steering, differential steering and travel with a load, with high flexibility and mobility. Multi-disc wet constant closed brake, spring brake and hydraulic release valve are used to ensure high braking safety.

Maximum travel speed: 1.2km/h.

Grade ability: 30%.

Hydraulic system

Adopt hydraulic pilot proportional controlled LUDV load sensing system, it can achieve load independent flow distribution, with accurate speed, sensitive operation, good stability and good fine motion performance. LUDV integrated main valve can achieve the compound operation of multiple movements, compact in structure and easy for maintenance. Innovative use of micro control adjustment technology can greatly improve the stability and accuracy of crane movements.

Main hoist winch and aux. hoist winch are with double pump confluence function, easy to achieve high/low speed control of the winches. Specialized slewing buffer circuit, the start and stop of slewing is smooth and soft, meeting the requirements of fine lifting operation.

Fuel tank capacity: 400L.

Electrical system

Electrical system mainly includes the following parts: engine control, monitoring instruments, auxiliary equipment, hydraulic system control, load moment limit, safety monitoring and etc.

Electrical system composition: conventional electrical system and PLC control system.

Conventional electrical system adopts 24V parallel circuit, and the wiring of electrical equipment adopts single wire system. The system includes power supply, start control, cab air conditioner and radio, illumination (light), wipers and etc.

The PLC control system includes the control of main winch, aux. winch, slewing, boom luffing and other movements, as well as engine condition monitoring. All movements are controlled by hydraulic proportional control technology. Through PLC logic control, it can effectively ensure the realization of all functions of the crane, and fully reflect the people-oriented design concept.

Engine system

Model: Weichai WP7G270E301;

Rated output power: 199kW/2000rpm;

Maximum torque / maximum torque speed: 1200N · m/1200-1500rpm;

Type: in-line, six cylinder, water-cooled, turbocharged and inter-cooler, electric injection, four-stroke diesel engine;

Environmental protection: in compliance with China III/Euro IIIA emission standard;

Fuel tank capacity: 400L.

Counterweight

Turntable counterweight is 21.6t in total, installed at the rear side of turntable. It is connected with turntable by pin shafts. Counterweight composition:

Counterweight tray 1 × 4t, left and right counterweight block 6 × 2t, central counterweight block 2 × 2.8t.

Hook block

There are 4 kinds of hooks, and the customers can choose flexibly according to their needs.

Name	80t	32t	16t	8t
Weight (t)	0.89	0.36	0.30	0.15
Number of pulley	7	3	1	-
Max. parts of line	12	7	3	1

Lubrication

According to the use frequency of the crane, a large number of maintenance and lubrication free seal structure are used to reduce the wear of parts, thus making crane maintenance more easy and convenient.

SAFETY PROTECTION MEASURES

This crane widely uses mechanical, electronic and hydraulic and other safety and warning devices to ensure the safe use of the machine. The safety devices include: load moment limiter, slewing lock device, boom backstop device, hoist limit switch, boom angle limiter, anemometer, level meter, slewing warning and hydraulic system relief valve, balance valve, hydraulic lock and etc.

Assembly mode & working mode selector switch

In assembly mode, rope over-wind protection device, boom angle limiter and load moment indicator are all out of service to provide convenience for crane assembly; in working mode, all safety devices are working normally.

Emergency stop button

Press this button in emergency condition to stop all crane movements.

Rope over-wind protection device

Rope over-wind protection devices for main and auxiliary winches are set on boom head to prevent the rope from being over-wound. When main winch and aux. winch hoist to a certain height, the over-wind indicator light on display will turn on, at the same time, the movement of hoisting up will be stopped by LMI automatically.

Rope over-release protection device

Rope end limiter is set on main and aux. hoist winches to prevent wire rope from over-releasing. When there are only three loops of rope left, the over-release indicator light on display will turn on, at the same time, the movement of lowering down will be stopped by LMI automatically.

Ratchet locking device

Ratchet locking device is used to lock the luffing winch so that boom is stopped and placed safely at non-working state.

Mechanical safety device

Slewing locking device is used to lock superstructure slewing when the crane is stopped; backstop devices are used to prevent boom and jib strut from tilting backward.

Boom angle limiter

When boom is raised to a specified angle, boom raising is stopped under the control of load moment limiter and hoist limit switch. When boom angle is less than the specified value, boom lowering is stopped under the control of load moment limiter and gives a warning sound.

Hook latch

All hook blocks are equipped with hook latch to prevent the hanging rope on the hook head from falling.

Hydraulic system safety protection device

Hydraulic system is equipped with hydraulic balance valve, hydraulic relief valve and other devices to ensure the stable and safe work of the system.

LMI system (Hirschmann)

Detection function: LMI can automatically detect parameters such as boom angle and lifting weight.

Display function: 7.0-inch color LCD display, show important parameters in lifting operation through text (Chinese or English) and graphics, such as load moment percentage, actual lifting weight, rated lifting weight, radius, boom length, angle, maximum lifting height, working condition code, parts of line, limit angle and information code.

Warning function: with complete pre-alarm and overload stop function. If it is detected that the actual weight exceeds the rated lifting capacity or boom angle exceeds the maximum value, LMI will send alarm and limit the current movement of the crane.

The system has self-diagnosis function.

Tricolor warning light

The light comprises three colors. When crane loading is below 90% of the rated capacity, the "green light" is on to indicate that the crane is operating in a safe area; when crane loading is below 90%~100% of the rated capacity, the "yellow light" is on to indicate that the crane is close to the rated load; when crane loading exceeds 100% of the rated capacity, both "red light" and "yellow light" will be on to indicate that the crane is overloaded and in the dangerous area, the control system will automatically cut off crane movement to dangerous direction.

SAFETY PROTECTION MEASURES

Audio and video alarm

When crawler crane is slewing, there is light and sound for warning.

Illumination light

There are illumination lights in front of turntable, above the cab or in the cab for night operation.

Rear view mirror

It is located outside the cab, so that the driver can easily observe the situation behind the machine.

Height light

It is installed on boom tip to give warning for high level operation.

Anemometer

It can detect the current wind speed and send signal to the monitor in operator's cab to remind the operator to pay attention to the wind load.

Level meter

It is equipped with bubbler type level meter, which can show the ground gradient and provide reference for the operator.

MAIN TECHNICAL PARAMETERS

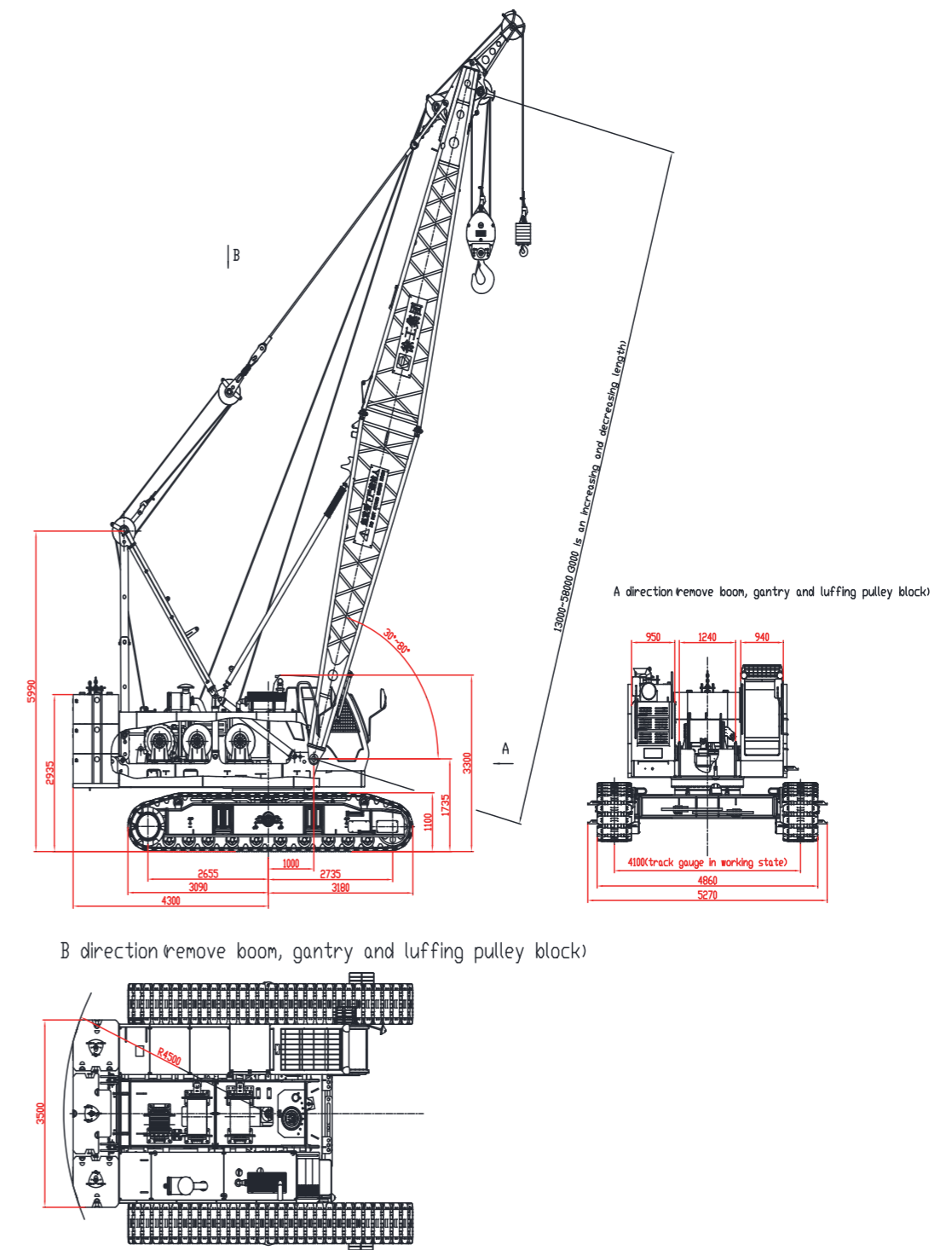

MAIN TECHNICAL PARAMETERS

Items		Unit	Parameters
Max. rated lifting capacity	Boom working condition	t	80
	Boom single top working condition	t	6.5
	Fixed jib working condition	t	12
Max. load moment	Boom working condition	t.m	288
	Fixed jib working condition	t.m	171.2
	Boom single top working condition	t.m	146.4
Dimension	Boom length	m	13~58
	Boom luffing angle	°	-3~80
	Fixed jib length	m	7~19
	Angle between boom and fixed jib	°	10, 30
	Boom single top	m	1.1
Speed	Hoist winch max. single line speed	m/min	128
	Boom luffing winch max. single line speed	m/min	70
	Max. slewing speed	rpm	2.4
	Max. travel speed	Km/h	1.2
Engine	Engine model	-	WP7
	Engine rated power	kW	199
	Emission standard	-	China III/Euro IIIA
Total vehicle mass (with 13m basic boom and 80t hook block)		t	61.5
Average ground pressure		MPa	0.08
Grade-ability		-	30%
Max. weight of single piece in transport state		t	37
Max. dimension of single piece (turntable) for transport (L × W × H)		m	12.7 × 3.4 × 3.4

10

XGC80-I CRAWLER CRANE

P11-P20 Lifting Capacity Tables in Typical Working Conditions

LIFTING CAPACITY TABLES IN TYPICAL WORKING CONDITIONS

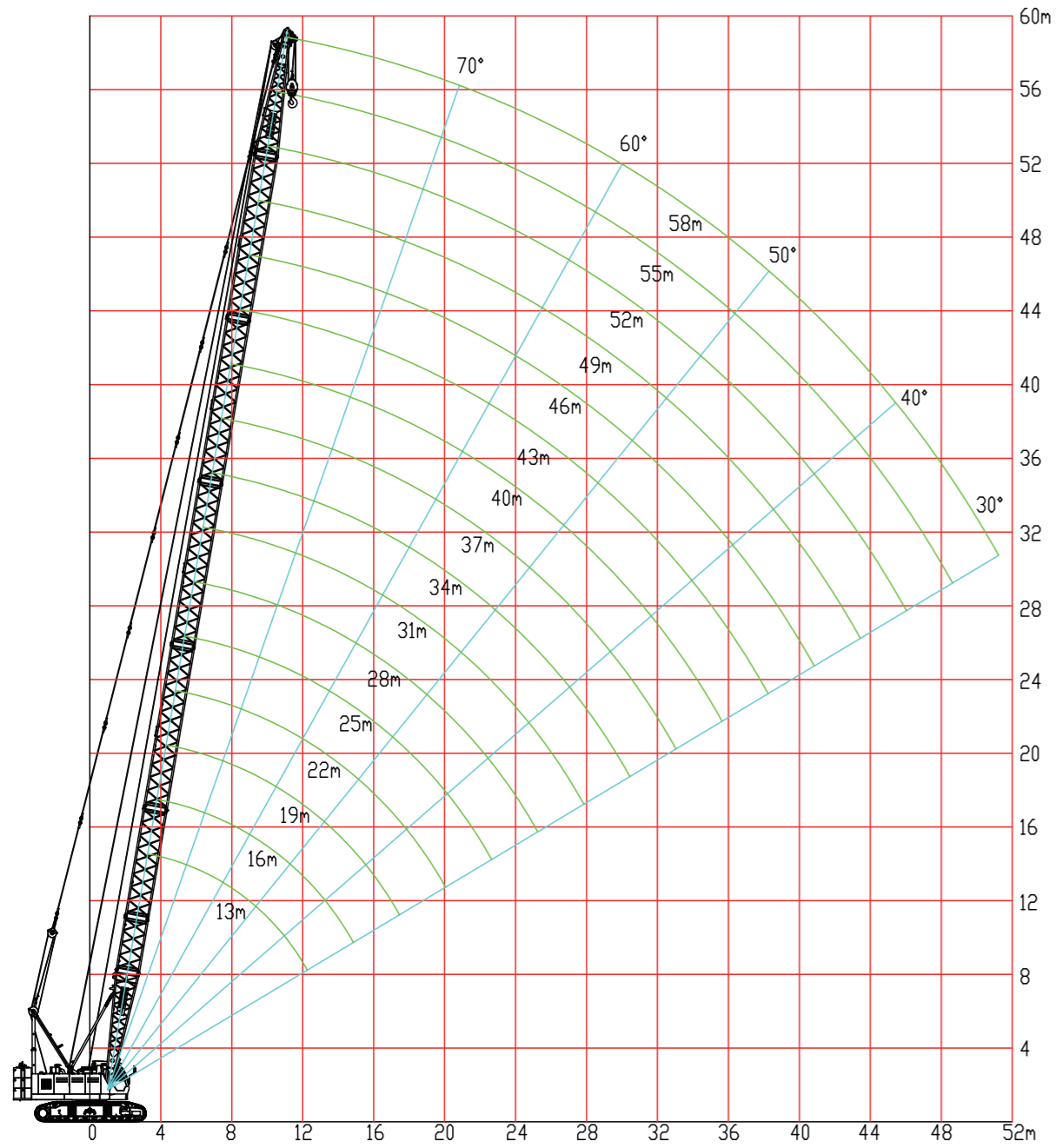

Working range of the crane in boom working condition

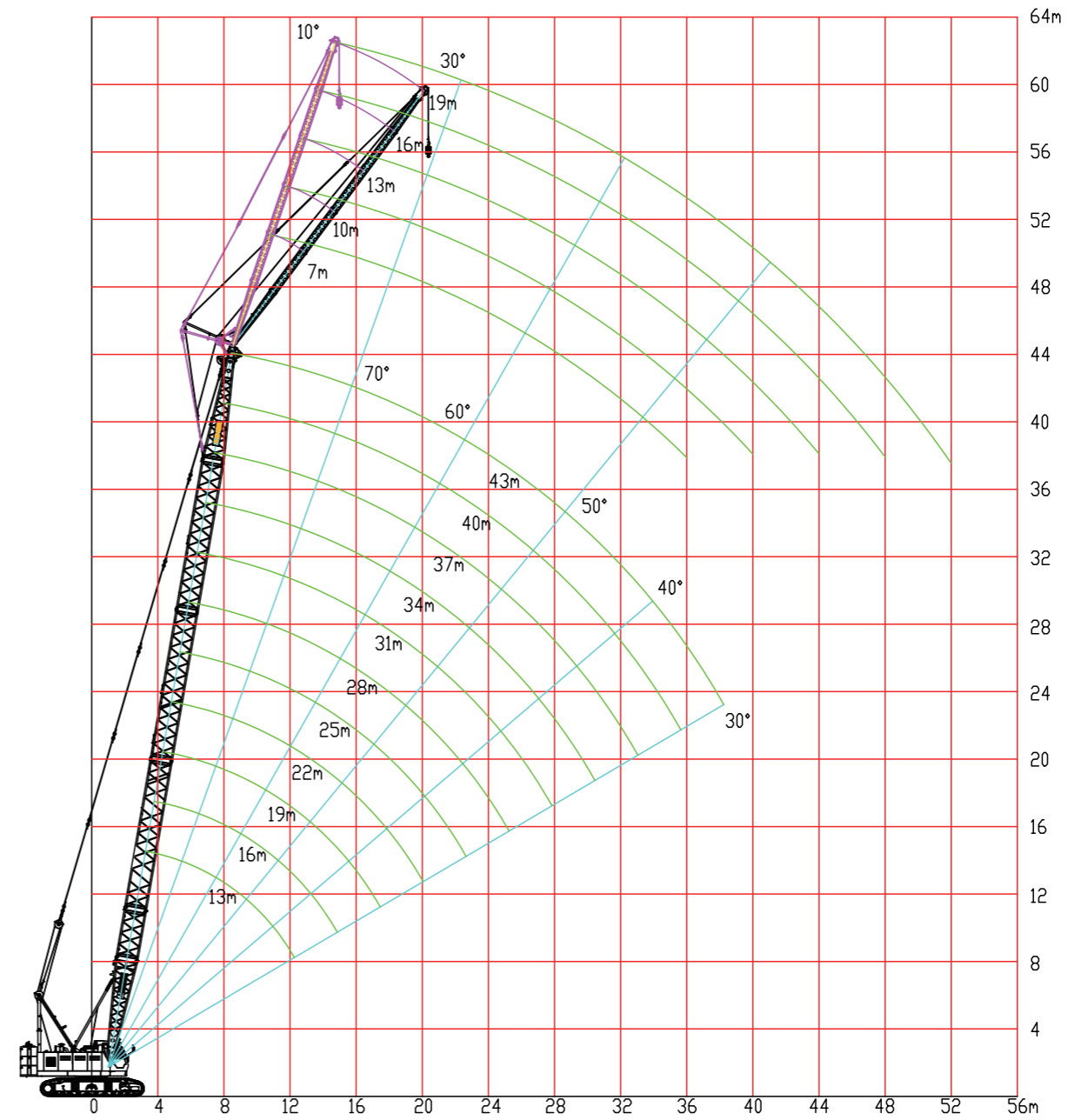

Working range of the crane in fixed jib working condition

LIFTING CAPACITY TABLES IN TYPICAL WORKING CONDITIONS

Lifting capacity tables in boom working condition

Lifting capacity tables for main boom									
Boom length (m)	13	16	19	22	25	28	31	34	Boom length (m)
Radius (m)									Radius (m)
3.6	80								3.6
4	71.5	68.0/4.2							4
5	56.5	55.5	55	47.5/5.3					5
6	43.5	42.7	41.9	41.5	40.9	35.2/6.5			6
7	34.5	34.3	34.2	33.7	32.7	32.1	31.7	28.2/7.5	7
8	28.5	28.4	28.4	28.3	27.9	27.3	26.8	26.3	8
9	24.2	24.0	23.9	23.8	23.6	23.4	23.2	22.6	9
10	20.9	20.9	20.8	20.7	20.6	20.5	20.1	19.9	10
12	16.4	16.3	16.3	16.2	16.1	16	15.9	15.8	12
14		13.3	13.3	13.2	13.1	13	12.9	12.8	14
16			11.1	11	10.9	10.8	10.7	10.6	16
18				9.4	9.3	9.2	9.1	9	18
20				8.2	8.1	8	7.9	7.8	20
22					7.1	7	6.9	6.8	22
24						6.2	6.1	5.9	24
26							5.4	5.3	26
28								4.7	28
30								4.2	30
Counterweight (t)	21.6	21.6	21.6	21.6	21.6	21.6	21.6	21.6	Counterweight (t)

Lifting capacity tables for main boom									
Boom length (m)	37	40	43	46	49	52	55	58	Boom length (m)
Radius (m)									Radius (m)
8	25.9								8
9	22.0	21.7	21.5						9
10	19.6	19.3	19.2	18.9	18.4	16.5/10.7	14.2/11		10
12	15.6	15.4	15.2	14.8	14.5	13.9	13.5	12.5	12
14	12.7	12.6	12.4	12.2	12.0	11.7	11.4	11.0	14
16	10.5	10.4	10.3	10.2	10.0	9.8	9.6	9.4	16
18	8.9	8.8	8.7	8.5	8.4	8.3	8.1	7.9	18
20	7.6	7.5	7.4	7.3	7.2	7	6.9	6.8	20
22	6.6	6.5	6.4	6.3	6.2	6	5.9	5.8	22
24	5.8	5.7	5.6	5.5	5.3	5.2	5.1	4.9	24
26	5.1	5	4.9	4.8	4.6	4.5	4.4	4.2	26
28	4.6	4.4	4.3	4.2	4.1	3.9	3.8	3.7	28
30	4.1	3.9	3.8	3.7	3.6	3.4	3.3	3.2	30
32	3.6	3.5	3.4	3.3	3.1	3	2.9	2.7	32
34		3.1	3	2.9	2.8	2.6	2.5	2.3	34
36			2.7	2.6	2.4	2.3	2.2	2	36
38			2.4	2.3	2.1	2	1.9	1.7	38
40				2	1.9	1.7	1.6	1.4	40
42					1.6	1.5	1.4	1.2	42
44						1.3	1.2	1	44
46						1.1	1		46
Counterweight (t)	21.6	21.6	21.6	21.6	21.6	21.6	21.6	21.6	Counterweight (t)

LIFTING CAPACITY TABLES IN TYPICAL WORKING CONDITIONS

Lifting capacity tables in fixed jib working condition (unit: t)

Radius	Boom 28m									
	Fixed jib length (m)									
	7		10		13		16		19	
	Jib angle(°)									
	10	30	10	30	10	30	10	30	10	30
9	12									
10	12		9.6							
12	12	9.9	9.1		7.2		5.6		4.2	
14	12	9.6	8.6	6.5	6.8		5.3		3.9	
16	10.7	9.4	8.2	6.3	6.5	4.8	5	3.7	3.7	
18	9.1	9.2	7.8	6.1	6.1	4.6	4.7	3.5	3.4	2.5
20	7.8	8	7.5	5.9	5.9	4.4	4.5	3.4	3.2	2.4
22	6.8	6.9	6.9	5.8	5.6	4.3	4.3	3.2	3	2.3
24	6	6.1	6.1	5.6	5.3	4.2	4	3.1	2.8	2.2
26	5.3	5.4	5.4	5.5	5.1	4.1	3.8	3	2.7	2
28	4.8	4.8	4.8	4.9	4.9	4	3.7	2.9	2.5	1.9
30	4.3	4.3	4.3	4.4	4.4	3.9	3.5	2.8	2.4	1.8
32	3.8	3.8	3.9	3.9	3.9	3.8	3.3	2.7	2.3	1.8
34			3.5	3.5	3.6	3.6	3.2	2.6	2.2	1.7
36					3.2	3.3	3	2.6	2	1.6
38						2.9	2.9	2.5	1.9	1.6
40							2.7	2.5	1.8	1.5
42									1.7	1.5
44										1.5
Counterweight	21.6t									

Radius	Boom 31m									
	Fixed jib length (m)									
	7		10		13		16		19	
	Jib angle(°)									
	10	30	10	30	10	30	10	30	10	30
9	12									
10	12		9.6							
12	12	9.9	9.2		7.2		5.6			
14	12	9.7	8.7	6.5	6.9		5.3		4	
16	10.6	9.5	8.3	6.3	6.6	4.8	5.1		3.7	
18	9	9.2	8	6.1	6.3	4.6	4.8	3.6	3.5	
20	7.7	7.9	7.6	6	6	4.5	4.6	3.4	3.3	2.4
22	6.7	6.8	6.8	5.8	5.7	4.4	4.4	3.3	3.1	2.3
24	5.9	6	6	5.7	5.5	4.2	4.1	3.2	2.9	2.2
26	5.2	5.3	5.3	5.4	5.3	4.1	4	3	2.8	2.1
28	4.6	4.7	4.7	4.8	4.8	4	3.8	2.9	2.6	2
30	4.1	4.2	4.2	4.3	4.3	4	3.6	2.8	2.5	1.9
32	3.7	3.7	3.8	3.8	3.8	3.9	3.5	2.7	2.4	1.8
34	3.3	3.3	3.4	3.4	3.4	3.5	3.3	2.7	2.3	1.7
36			3	3.1	3.1	3.2	3.1	2.6	2.2	1.7
38				2.7	2.8	2.8	2.8	2.6	2	1.6
40					2.5	2.5	2.5	2.5	1.9	1.6
42							2.3	2.4	1.8	1.5
44								2.1	1.8	1.5
46										1.5
Counterweight	21.6t									

TYPICAL WORKING CONDITIONS

Lifting capacity tables in fixed jib working condition (unit: t)

Radius	Boom 34m									
	Fixed jib length (m)									
	7		10		13		16		19	
	Jib angle(°)									
	10	30	10	30	10	30	10	30	10	30
10	12									
12	12	9.9	9.2		6.5					
14	12	9.7	8.8	6.5	6.5		5.3		4	
16	10.4	9.5	8.4	6.3	6.5	4.8	5.1		3.8	
18	8.9	9.1	8.1	6.2	6.3	4.7	4.9	3.6	3.6	
20	7.6	7.8	7.7	6	6.1	4.5	4.7	3.5	3.4	2.4
22	6.6	6.7	6.7	5.9	5.8	4.4	4.4	3.3	3.2	2.3
24	5.8	5.9	5.9	5.8	5.6	4.3	4.2	3.2	3	2.2
26	5.1	5.2	5.2	5.3	5.2	4.2	4.1	3.1	2.9	2.2
28	4.5	4.6	4.6	4.7	4.6	4.1	3.9	3	2.7	2.1
30	4	4.1	4.1	4.2	4.1	4	3.7	2.9	2.6	2
32	3.6	3.6	3.6	3.7	3.7	3.8	3.6	2.8	2.5	1.9
34	3.2	3.2	3.2	3.3	3.3	3.4	3.3	2.7	2.4	1.8
36	2.8	2.8	2.9	3	3	3.1	3	2.7	2.3	1.7
38			2.6	2.6	2.7	2.7	2.7	2.6	2.2	1.7
40			2.3	2.3	2.4	2.4	2.4	2.5	2.1	1.6
42					2.2	2.2	2.2	2.3	2	1.6
44							2	2	1.9	1.5
46								1.8	1.8	1.5
48									1.6	1.5
Counterweight	21.6t									

Lifting capacity tables in fixed jib working condition (unit: t)

Radius	Boom 37m									
	Fixed jib length (m)									
	7		10		13		16		19	
	Jib angle(°)									
	10	30	10	30	10	30	10	30	10	30
10	12									
12	12	9.9	6.5		6.5					
14	12	9.7	6.5	6.5	6.5		5.4		4	
16	10.2	9.5	6.5	6.3	6.5	4.8	5.1		3.8	
18	8.7	8.9	6.5	6.2	6.4	4.7	4.9	3.6	3.6	
20	7.5	7.7	6.5	6	6.2	4.5	4.7	3.5	3.4	2.5
22	6.5	6.6	6.5	5.9	5.9	4.4	4.5	3.4	3.3	2.4
24	5.7	5.8	5.7	5.8	5.7	4.3	4.3	3.3	3.1	2.3
26	5	5.1	5	5.2	5.1	4.2	4.2	3.2	2.9	2.2
28	4.4	4.5	4.5	4.6	4.5	4.1	4	3.1	2.8	2.1
30	3.9	4	4	4.1	4	4.1	3.8	3	2.7	2
32	3.5	3.5	3.5	3.6	3.6	3.7	3.6	2.9	2.5	1.9
34	3.1	3.1	3.1	3.2	3.2	3.3	3.2	2.8	2.4	1.9
36	2.7	2.8	2.8	2.9	2.9	3	2.9	2.7	2.3	1.8
38	2.4	2.4	2.5	2.5	2.6	2.6	2.6	2.7	2.2	1.7
40		2.1	2.2	2.3	2.3	2.4	2.3	2.4	2.1	1.7
42			2	2	2	2.1	2.1	2.2	2.1	1.6
44						1.8	1.8	1.8	1.9	1.6
46							1.6	1.6	1.7	1.5
48								1.4	1.5	1.5
50									1.3	1.4
52										1.2
Counterweight	21.6t									

TYPICAL WORKING CONDITIONS

Lifting capacity tables in fixed jib working condition (unit: t)

Radius	Boom 40m									
	Fixed jib length (m)									
	7		10		13		16		19	
	Jib angle(°)									
	10	30	10	30	10	30	10	30	10	30
12	6.5		6.5							
14	6.5	6.5	6.5		6.5		5.3		4	
16	6.5	6.5	6.5	6.3	6.5		5.1		3.9	
18	6.5	6.5	6.5	6.2	6.4	4.7	5		3.7	
20	6.5	6.5	6.5	6.1	6.2	4.6	4.8	3.5	3.5	2.5
22	6.4	6.5	6.4	5.9	6	4.5	4.6	3.4	3.3	2.4
24	5.5	5.7	5.6	5.8	5.7	4.4	4.4	3.3	3.2	2.3
26	4.8	5	4.9	5.1	5	4.3	4.2	3.2	3	2.2
28	4.3	4.4	4.3	4.5	4.4	4.2	4.1	3.1	2.9	2.1
30	3.8	3.8	3.8	4	3.9	4.1	3.9	3	2.7	2.1
32	3.3	3.4	3.4	3.5	3.5	3.6	3.5	2.9	2.6	2
34	2.9	3	3	3.1	3.1	3.2	3.1	2.8	2.5	1.9
36	2.6	2.6	2.7	2.8	2.7	2.9	2.8	2.8	2.4	1.8
38	2.3	2.3	2.4	2.4	2.4	2.5	2.5	2.6	2.3	1.8
40	2	2	2.1	2.1	2.2	2.3	2.2	2.3	2.2	1.7
42	1.8	1.8	1.9	1.9	1.9	2	1.9	2.1	2	1.7
44			1.6	1.6	1.7	1.7	1.7	1.8	1.7	1.6
46				1.4	1.5	1.5	1.5	1.6	1.5	1.6
48					1.3	1.3	1.3	1.4	1.4	1.5
50							1.1	1.2	1.2	1.3
52								1	1	1.1
54										1.1
Counterweight	21.6t									

Lifting capacity tables in fixed jib working condition (unit: t)

Radius	Boom 43m									
	Fixed jib length (m)									
	7		10		13		16		19	
	Jib angle(°)									
	10	30	10	30	10	30	10	30	10	30
12	6.5		6.5							
14	6.5	6.5	6.5		6.5		5.3			
16	6.5	6.5	6.5	6.4	6.5		5.1		3.9	
18	6.5	6.5	6.5	6.2	6.4	4.7	4.9		3.7	
20	6.5	6.5	6.5	6.1	6.2	4.6	4.8	3.5	3.5	
22	6.2	6.3	6.3	6	6	4.5	4.6	3.4	3.4	2.4
24	5.4	5.6	5.5	5.8	5.6	4.4	4.5	3.3	3.2	2.3
26	4.7	4.8	4.8	5	4.9	4.3	4.3	3.2	3.1	2.2
28	4.1	4.2	4.2	4.4	4.3	4.2	4.1	3.1	2.9	2.2
30	3.6	3.7	3.7	3.9	3.8	4	3.8	3	2.8	2.1
32	3.2	3.3	3.3	3.4	3.3	3.5	3.4	3	2.7	2
34	2.8	2.9	2.9	3	2.9	3.1	3	2.9	2.6	2
36	2.5	2.5	2.5	2.6	2.6	2.8	2.6	2.8	2.5	1.9
38	2.2	2.2	2.2	2.3	2.3	2.4	2.3	2.5	2.4	1.8
40	1.9	1.9	2	2	2	2.1	2.1	2.2	2.1	1.8
42	1.7	1.7	1.7	1.8	1.8	1.9	1.8	2	1.8	1.7
44	1.4	1.4	1.5	1.5	1.6	1.6	1.6	1.7	1.6	1.7
46			1.3	1.3	1.4	1.4	1.4	1.5	1.4	1.6
48				1.1	1.1	1.2	1.2	1.2	1.3	1.3
50						1	1	1	1.1	1.2
52										1
54										1
Counterweight	21.6t									

TRANSPORT OF CRANE PARTS

21

XGC80-I CRAWLER CRANE

P22-P26 TRANSPORT PLAN OF CRANE PARTS

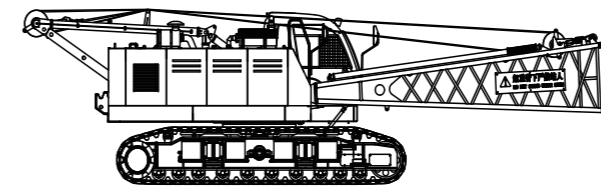

Basic crane transport plan I × 1

L	12.71 m
W	3.46 m
H	3.35 m
W	37.0 t

Include left and right crawler tracks, luffing sheave block and boom butt

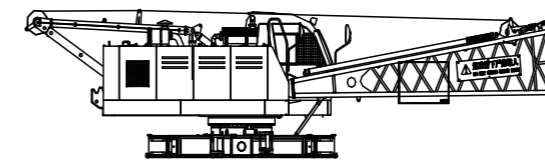

Basic machine transport plan B × 1

L	12.71 m
W	3.46 m
H	3.00 m
W	22.0 t

Include luffing pulley block, outriggers and boom butt

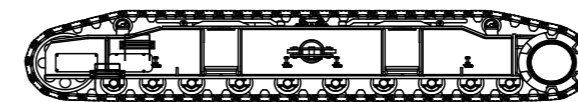

Left track frame × 1

L	6.28 m
W	0.98 m
H	1.10 m
W	8.51 t

Used when it is not transported with basic machine



Right track frame × 1

L	6.28 m
W	0.98 m
H	1.10 m
W	8.51 t

Used when it is not transported with basic machine

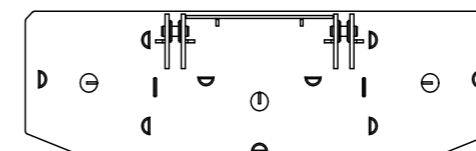

Counterweight tray × 1

L	3.8 m
W	1.0 m
H	0.26 m
W	4.0 t

TRANSPORT OF CRANE PARTS

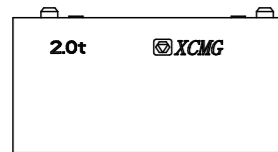

Left counterweight block	× 3
L	1.0 m
W	0.95 m
H	0.59 m
W	2.0 t

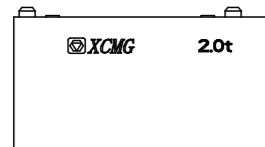

Right counterweight block	× 3
L	1.0 m
W	0.95 m
H	0.59 m
W	2.0 t

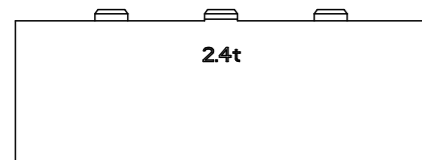

Middle counterweight block	× 2
L	1.8 m
W	0.83 m
H	0.55 m
W	2.8 t

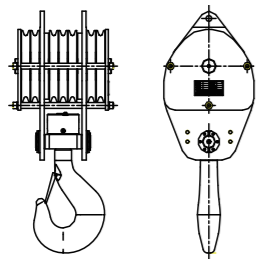

80t capacity hook block	× 1
L	0.71 m
W	0.63 m
H	1.65 m
W	0.89 t

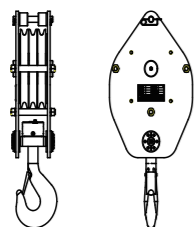

32t capacity hook block	× 1
L	0.34 m
W	0.63 m
H	1.35 m
W	0.36 t

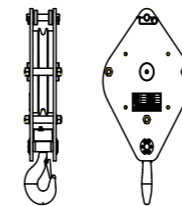

16t capacity hook block	× 1
L	0.26 m
W	0.62 m
H	1.1 m
W	0.30 t

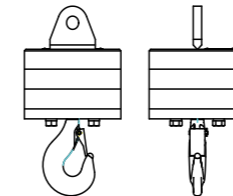

8t capacity hook block	× 1
L	0.32 m
W	0.32 m
H	0.57 m
W	0.15 t

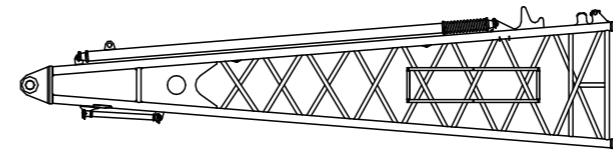

6.5m boom butt	× 1
L	6.67 m
W	1.60 m
H	1.52 m
W	1.09 t

Include boom butt, boom backstop, connecting rod, it is used when not transporting with basic machine

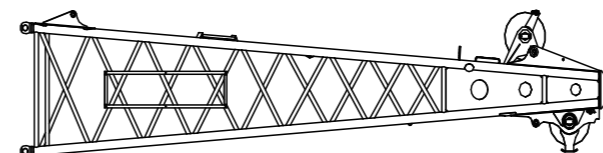

6.5m boom top	× 1
L	7.1 m
W	1.51 m
H	1.48 m
W	0.98 t

Include catwalk

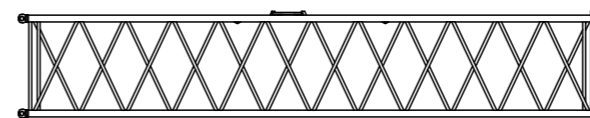

9m boom insert	× 4
L	9.10 m
W	1.59 m
H	1.37 m
W	0.78 t

Include catwalk

TRANSPORT OF CRANE PARTS

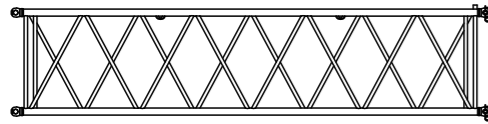

6m boom insert		× 1
L	6.10 m	
W	1.59 m	
H	1.37 m	
W	0.54 t	

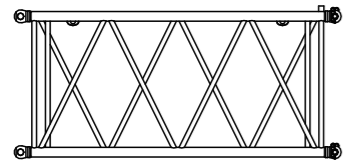

3m boom insert		× 1
L	3.10 m	
W	1.59 m	
H	1.37 m	
W	0.32 t	

Include catwalk

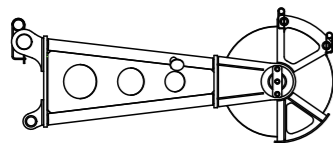

Boom single top		× 1
L	1.40 m	
W	0.63 m	
H	0.56 m	
W	0.1 t	

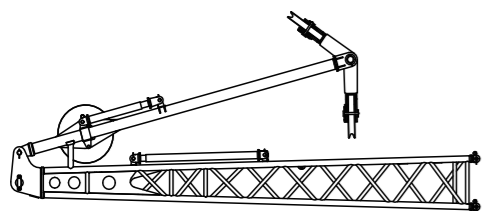

Fixed jib butt (with strut)		× 1
L	4.11 m	
W	0.70 m	
H	1.65 m	
W	0.42 t	

Include fixed jib butt, fixed jib strut. Front backstop rod, rear backstop rod and etc.

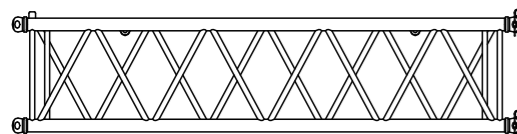

3m fixed jib insert		× 2
L	3.06 m	
W	0.66 m	
H	0.49 m	
W	0.11 t	

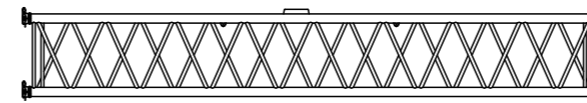

6m fixed jib insert		× 1
L	6.06 m	
W	0.66 m	
H	0.49 m	
W	0.19 t	

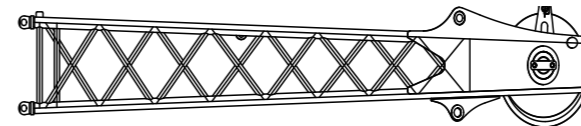

Fixed jib top		× 1
L	3.33 m	
W	0.66 m	
H	0.64 m	
W	0.22 t	

Note: the transport weight and dimension of the main parts of the crane are theoretical design values, which may be slightly different due to manufacturing errors.

